

# Junkers JU 52

JUNKERS JU 52/3M

Originally designed as a civilian transport aircraft, the JU 52 soon became one of Germany's important basic aircraft. In spite of slow speed, ungainly performance and obsolescence the JU 52 performed in an action combat role throughout WW II. Many versions were built from the original air frame, including float planes, ski planes, glide tow planes, and a magnetic mine destroyer. The German Air Force accepted the first military conversion of the JU 52 in 1934 and 1935. This aircraft saw early combat action. The outbreak of the Spanish Civil War provided the combat background, twenty JU 52's being sent to Spanish Morocco. In 1936 the famed "Condor Legion" was formed manned by "volunteer" German Air Force pilots and crews, continuing and expanding combat actions throughout Spanish Civil War. JU 52's became a major factor in Germany's early lightning attacks ("Blitzkrieg") in Norway, Denmark, and the Low Countries. They flew tons of equipment and thousands of troops into the Balkans and Greece and the invasion of Russia in June of 1941. The end of WW II witnessed the return of the now very obsolete JU 52 to it's original role . . . civilian freighter and transport.

# PROFILE SERIES



**MODEL PRODUCTS**  
 126 GROESBECK HIGHWAY  
 MOUNT CLEMENS, MICHIGAN  
 48043

**PLEASE READ THIS FIRST**

Before you begin, read the instructions very carefully. Study the illustrations and become familiar with the pieces before you start assembly of your model. Following the procedures given, test-fit all parts before cementing, this way you will become acquainted with the location of parts when it comes time to use cement. The highest quality styrene goes into the making of each MPC model. Only paint and cement made for styrene should be used. Before test fitting parts, trim off excess "flash". To join parts, use cement sparingly. Apply cement to very small parts with a toothpick. For removing parts from the "runners" it is best to use your modelers knife, do not attempt to twist them off.

When painting your model follow the painting tips in each step. It is best to paint the very small parts while they are still on the runners. For realism use flat colors and use them carefully.

You should have no trouble assembling your kit if the instructions are followed properly.

ASSEMBLY NUMBERS (2)

PART NUMBERS 20

CLEAR PARTS (1)

DO NOT CEMENT →

CEMENT - - - - - →

1

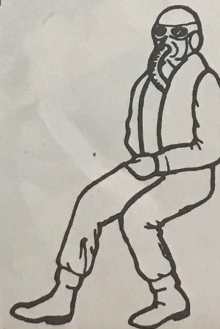

NOTE: Paint all members of flight crew the same paint scheme.

Mask	BLACK
Hose	BLACK
Pants	GREY
Jacket	DARK GREY
Helmet	BROWN
Boots	BLACK
Mae West	YELLOW
Goggles	BLACK (Lenses BLUE)
Hands	BLACK (Gloves)

2

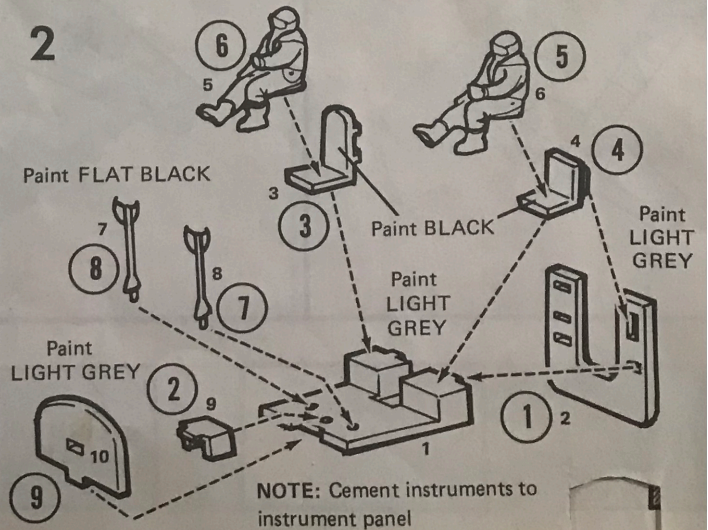

**3** Paint all inside surfaces  
LIGHT GREY.

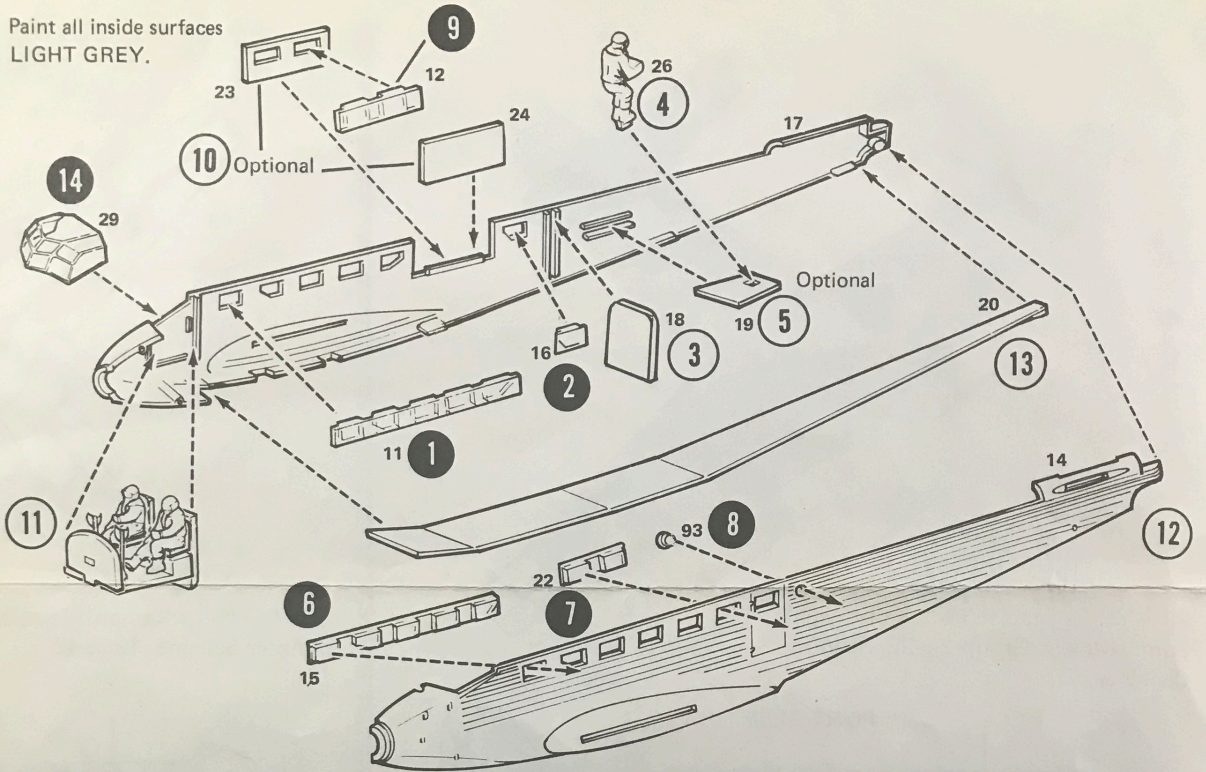

**4**

**17**  
Repeat steps 5 thru 16  
for other side.

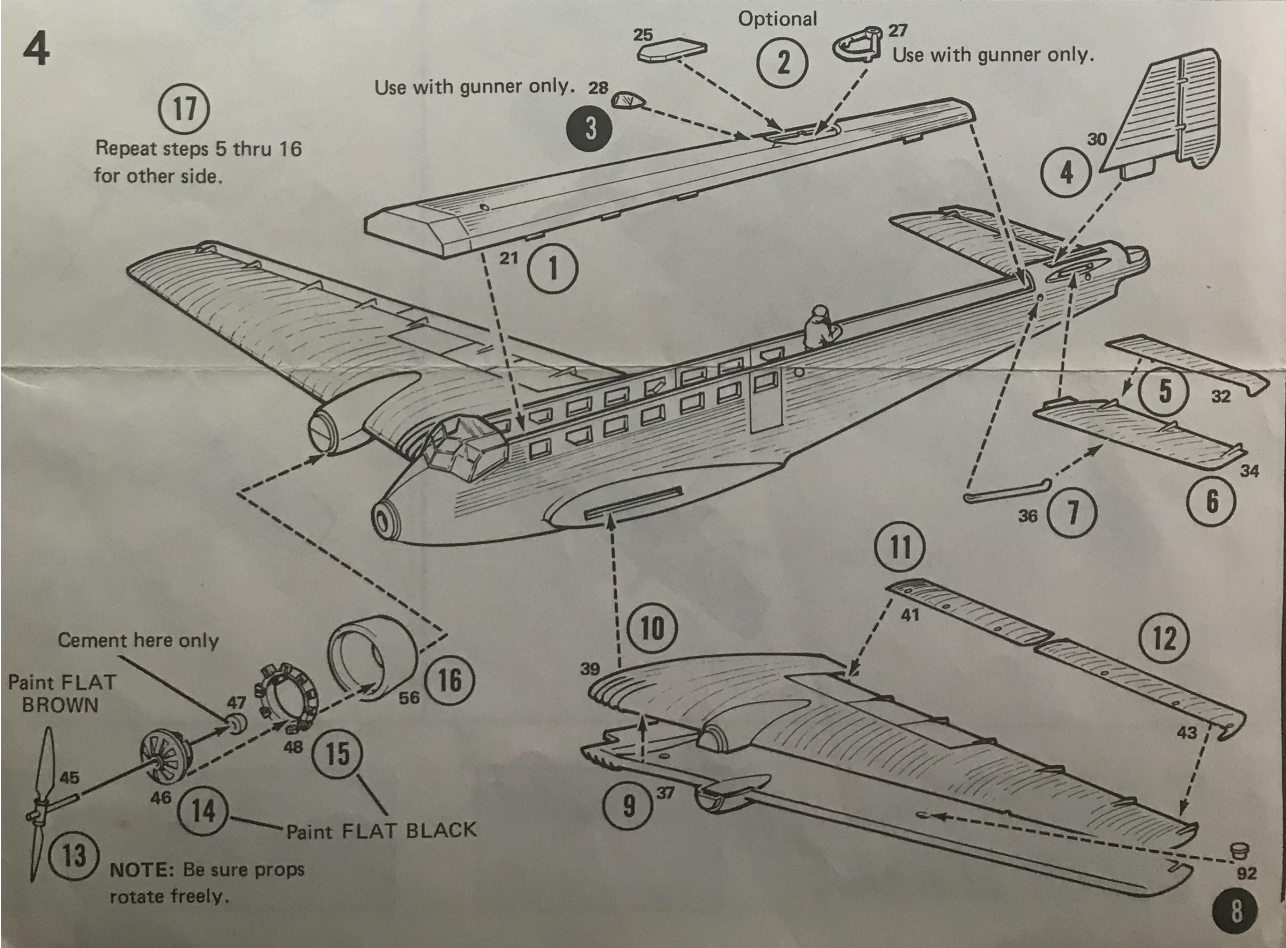

5

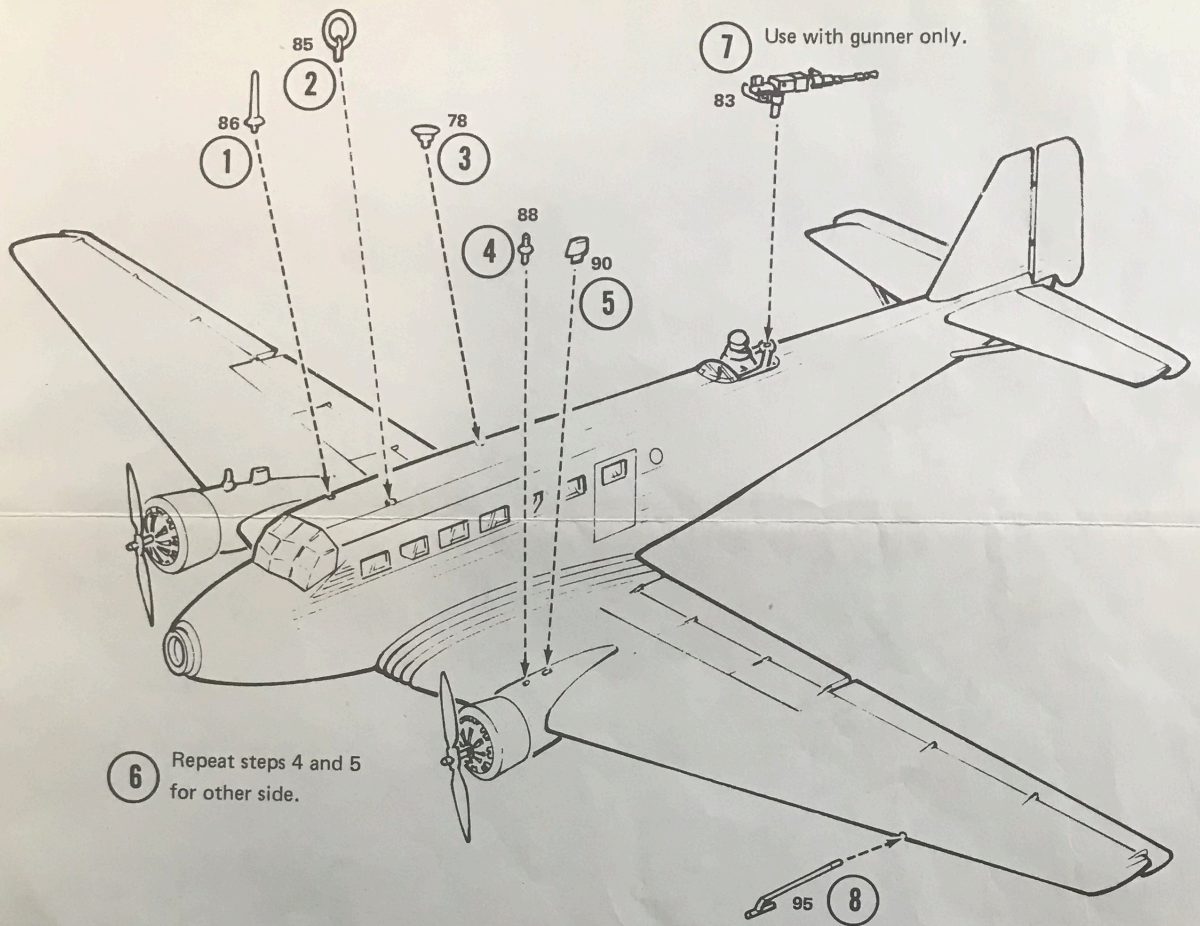

6

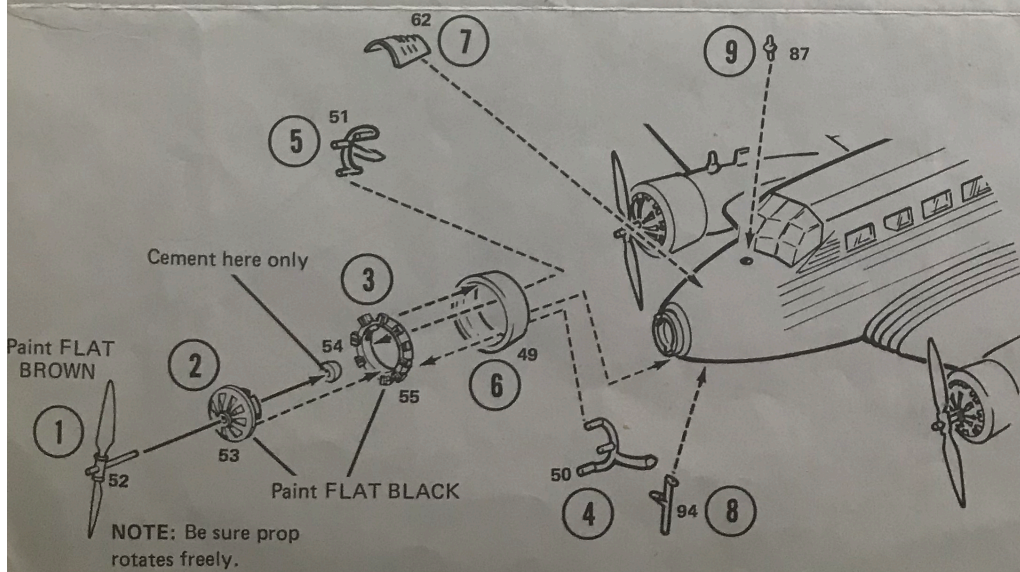

7

NOTE: Be sure wheels rotate freely.

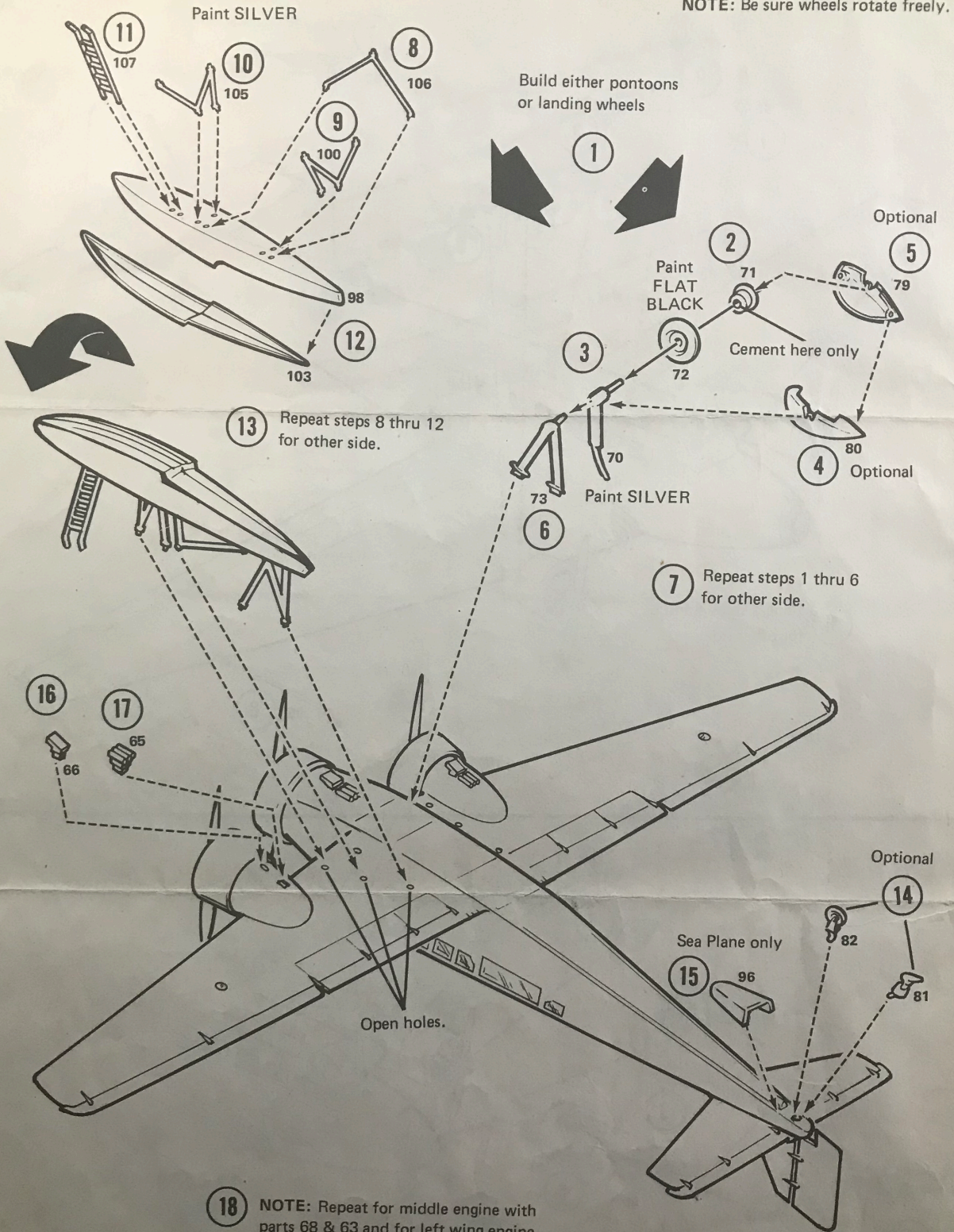

11 107  
10 105  
9 100  
8 106  
12 98  
103

13 Repeat steps 8 thru 12 for other side.

1 71  
2 72  
3 70  
4 80  
5 79  
6 73  
7 Repeat steps 1 thru 6 for other side.

14 82  
15 96  
81

16 66  
17 65

18 NOTE: Repeat for middle engine with parts 68 & 63 and for left wing engine use parts 64 & 67.

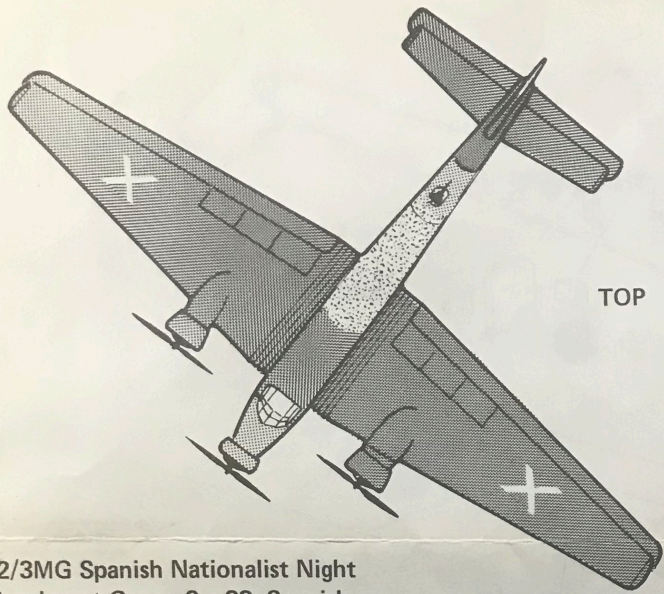

TOP

JU 52/3MG Spanish Nationalist Night  
Bombardment Group 2-g-22; Spanish  
Civil War.

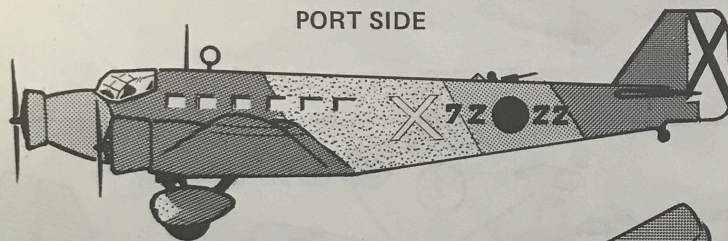

PORT SIDE

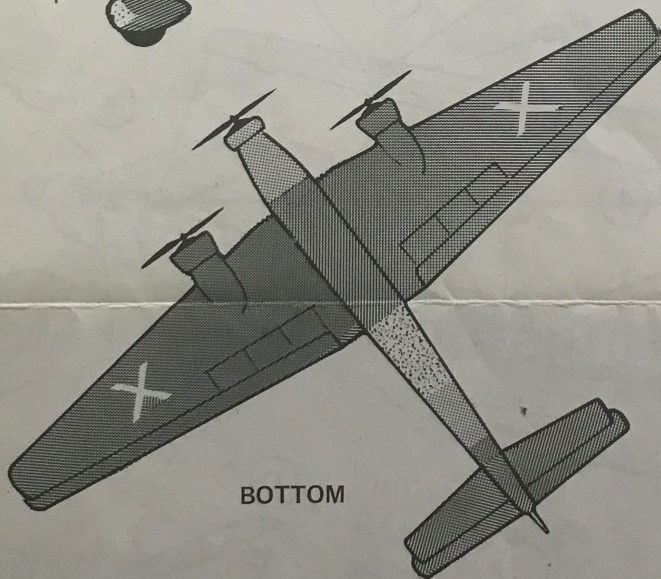

BOTTOM

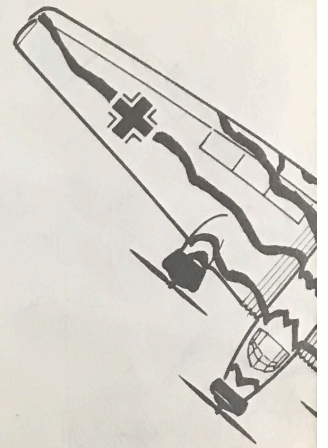

JU 52/3M of Kampffliegerschule " " "  
Winter Scheme, 1942-43

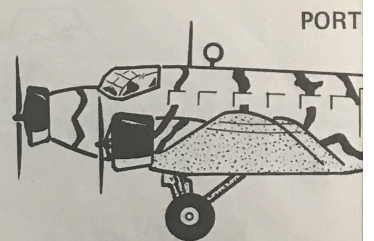

PORT

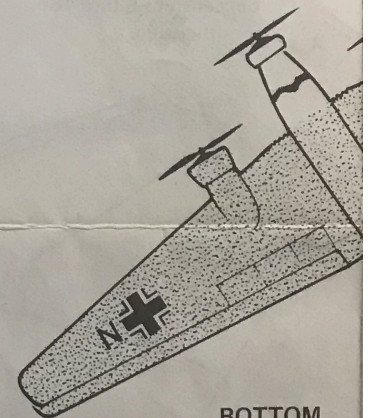

BOTTOM

(USE FLAT COLORS)

**COLOR SCHEME**

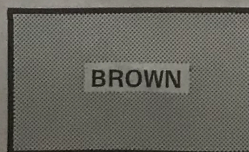

BROWN



OLIVE



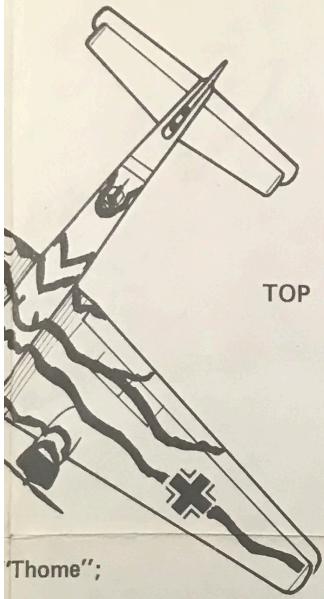

TOP

"Thome";

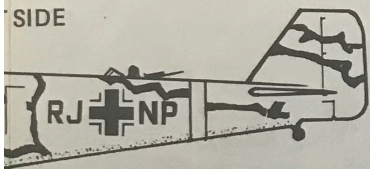

SIDE

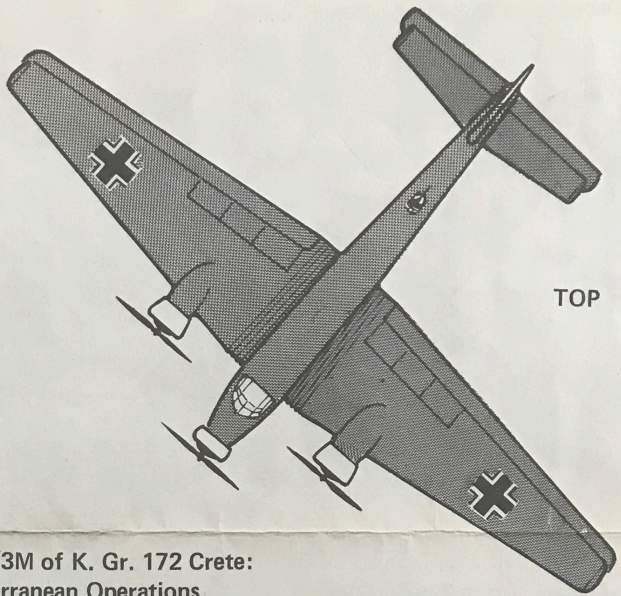
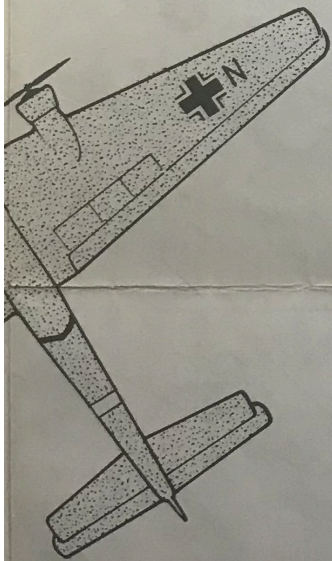

TOP

JU 52/3M of K. Gr. 172 Crete:  
Mediterranean Operations

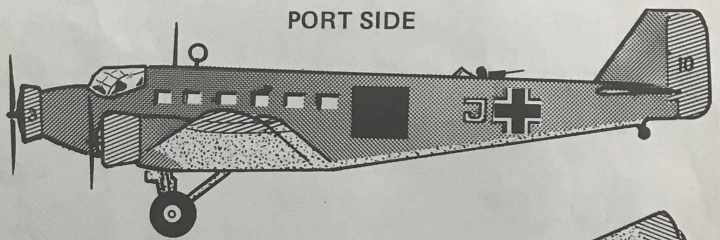

PORT SIDE

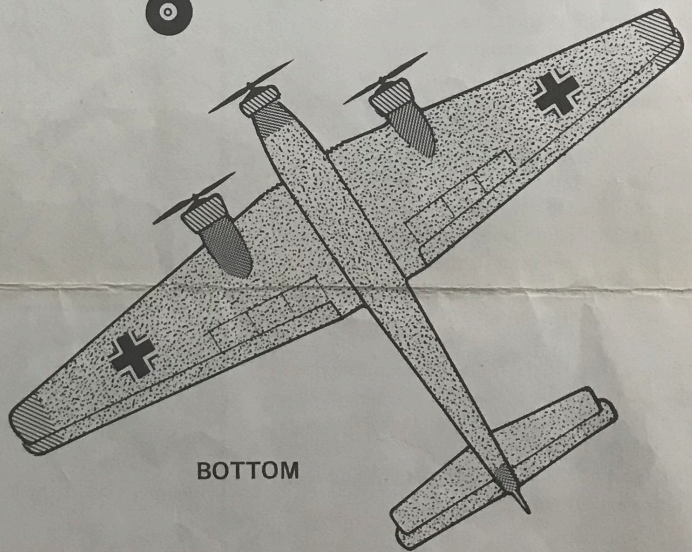

BOTTOM



YELLOW

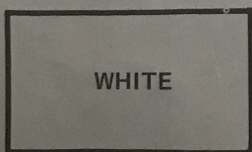

WHITE



LIGHT BLUE

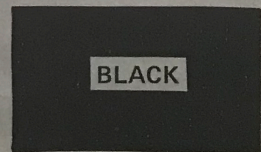

BLACK