

Revell

CAMARO Z-28

7248 3800

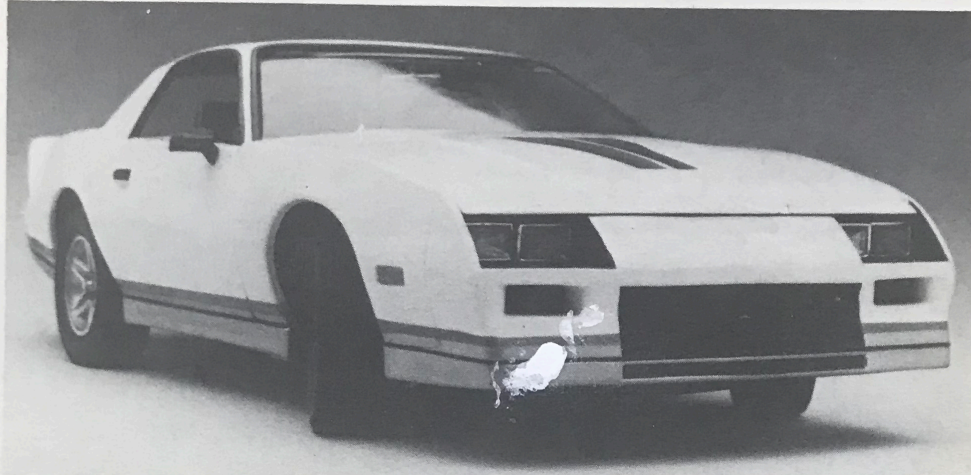

1967 was the first model year for the Camaro. It was created to directly compete with Ford's very successful Mustang, first introduced in 1965.

Several versions were offered that first year including the Z-28, Rally Sport and Super Sport. Convertibles were also available from 1967 through 1969. In 1973, the Luxury Touring model, known as the LT, was introduced. The Berlinetta took its place in 1979. Throughout the years Camaro has had three distinct body styles. The second body design occurred in the 1970½ model. Its lines resembled those of an Italian sports car. 1982 marked the third body change for the Camaro.

The 1982 Camaro was redesigned with the assistance of computer technology. "Motor Trend"

magazine named the 1982 Z-28 its "Car of the Year" after it tested high in several categories. 1983 has brought virtually few changes to the Camaro after its major change in '82. A new 5 speed transmission by Borg-Warner is standard on both the Z-28 and the Berlinetta. The Z-28 sports a 5 liter, 4 bbl., V-8 engine as standard, while a 2.8 liter, 2 bbl., V-6 engine is standard for the Berlinetta. All models have the same exterior dimensions:

SPECIFICATIONS:

Wheelbase: 101"
Overall Length: 187.8"
Overall Width: 72.8"
Overall Height: 49.8"
Tread Front/Rear: 60.7"/61.6"

ENGLISH: ASSEMBLY DRAWINGS SHOULD BE REVIEWED BEFORE PROCEEDING WITH CONSTRUCTION. A NUMBER IDENTIFIES EACH PLASTIC PART FOR YOUR CONVENIENCE. PAINT SMALL PARTS ON RUNNER BEFORE REMOVING. ALLOW PAINT TO DRY THOROUGHLY BEFORE CONTINUING ASSEMBLY OF KIT. SCRAPE CHROME OR PAINT AT AREA TO BE GLUED. WASH PLASTIC IN MILD DETERGENT SOLUTION. RINSE AND LET AIR DRY FOR BETTER PAINT AND DECAL ADHESION.

FRANCAIS: EXAMINER LES SCHEMAS D'ASSEMBLAGE AVANT DE COMMENCER LA CONSTRUCTION. UN NUMERO IDENTIFIE CHAQUE PIECE DE PLASTIQUE POUR PLUS DE FACILITE. PEINDRE LES PETITES PEICES SUR LE SUPPORT AVANT DE LES ENLEVER. LAISSER LA PEINTURE SECHER COMPLETEMENT AVANT DE CONTINUER L'ASSEMBLAGE

DU KIT. GRATTER LE CHROME OU LA PEINTURE SUR LES SURFACE A COLLER. LAVER LE PLASTIQUE DANS UNE SOLUTION DE DETERGENT LEGERE, RINCER ET LAISSER SECHER A L'AIR POUR UNE MEILLEURE ADHERENCE DE LA PEINTURE ET DES DECALS.

ESPAÑOL: DIBUJOS DE ENSAMBLAJE DEBEN SER REPASADOS ANTES DE SEGUIR CON LA CONSTRUCCION. UN NUMERO IDENTIFICA CADA PARTE DEL PLASTICO PARA SU CONVENIENCIA. PINTA PARTES PEQUENAS DEL KIT ANTES DE QUITARLAS. DEJE SECAR BIEN LA PINTURA ANTES DE SEGUIR EL ENSAMBLAJE. RASPE EL CROMO O LA PINTURA DEL SITIO ANTES DE SER PEGADO. LAVE EL PLASTICO EN UNA SOLUCION SUAVE DETERGENTE, ENJUAGUE, Y DEJE SECAR EN EL AIRE PARA MEJOR ADHESION DE LA PINTURA Y CALCOMANIA.



GLUE
COLLE
PEGA



NO GLUE REQUIRED
LA COLLE N'EST PAS NECESSAIRE
NO NECESITA PEGA



DO IT THIS MANY TIMES
LE FAIRE CE NOMBRE DE FOIS
HAGALO ESTA CANTIDAD DE VECES

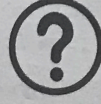

OPTIONAL
FACULTATIF
OPCIONAL

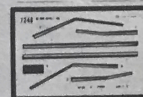

APPLY DECALS
COLLER LES DECALCOMANIES
APLICAR CALCAS



SHOWN ASSEMBLED
VU ASSEMBLE
MOSTRADO ARMADO



CLEAR
TRANSPARENT
TRANSPARENTE



WHITE
BLANC
BLANCO



CHROME
LE CHROME
EL CROMO

A	MATT BLACK	NEGRO MATE	NOIR MAT
B	STEEL	ACERO	ACIER
C	SILVER	PLATA	ARGENT
D	MEDIUM BLUE	AZUL MEDIO	BLEU MOYEN
E	WHITE	BLANCO	BLANC
F	RED	ROJO	ROUGE
G	ORANGE	ANARANJADO	ORANGE
H	LIGHT BROWN	MARRON CLARO	MARRON CLAIR
I	GOLD	ORO	DORE

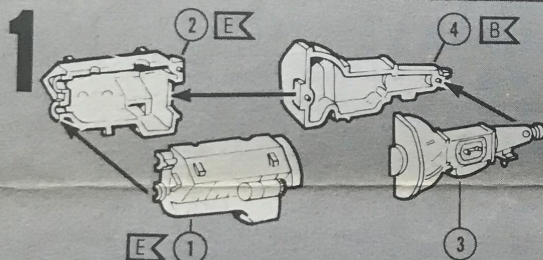
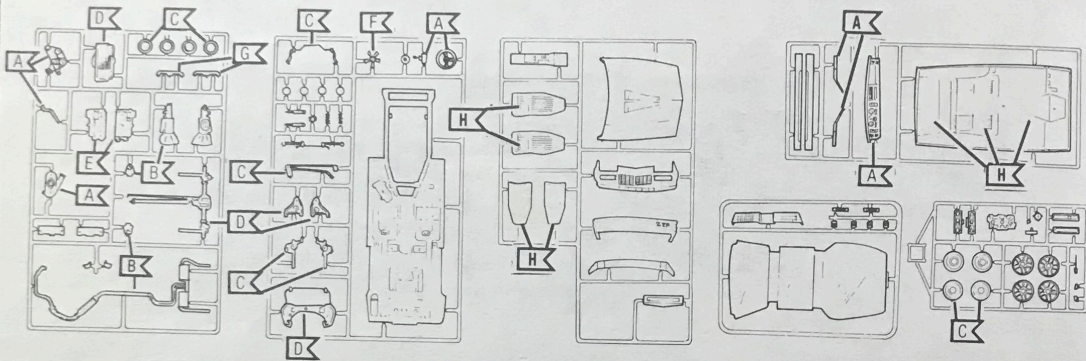

- 1 ENGINE - LEFT HALF
- 2 ENGINE - RIGHT HALF
- 3 TRANSMISSION - LEFT HALF
- 4 TRANSMISSION - RIGHT HALF

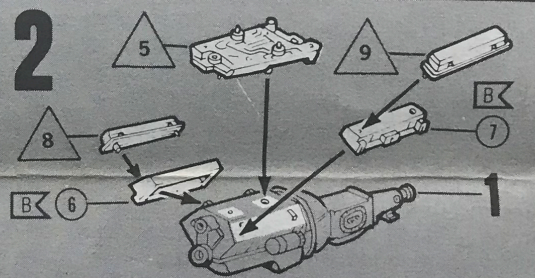

- 5 CROSSFIRE INTAKE MANIFOLD (CHROME)
- 6 HEAD - RIGHT
- 7 HEAD - LEFT
- 8 VALVE COVER - RIGHT (CHROME)
- 9 VALVE COVER - LEFT (CHROME)

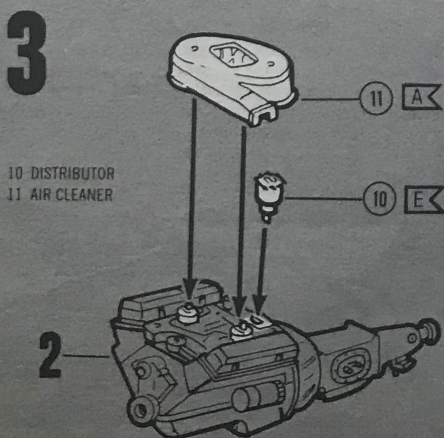
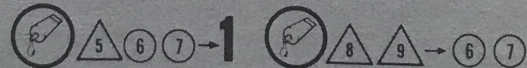

- 10 DISTRIBUTOR
- 11 AIR CLEANER

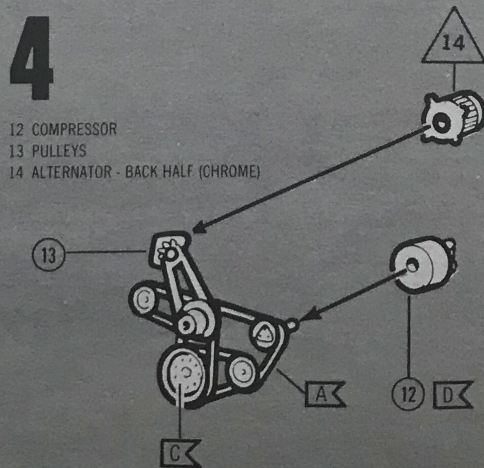
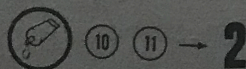

- 12 COMPRESSOR
- 13 PULLEYS
- 14 ALTERNATOR - BACK HALF (CHROME)

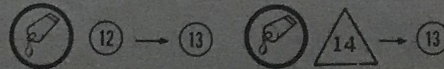

5

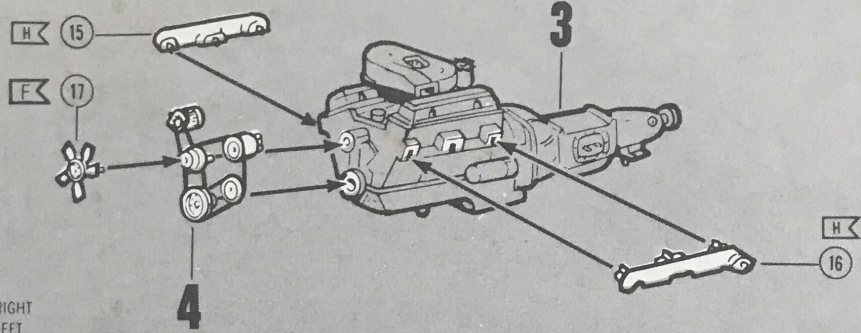

15 EXHAUST HEADER - RIGHT
 16 EXHAUST HEADER - LEFT
 17 FAN

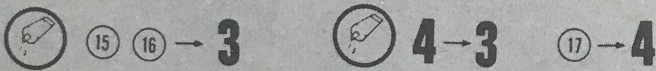

6

4X

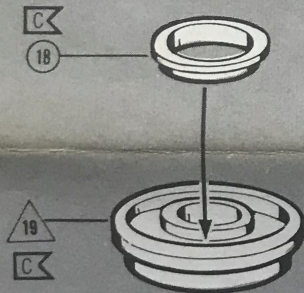

18 BRAKE DISC (4 PARTS)
 19 WHEEL - INSIDE HALF (CHROME) (4 PARTS)

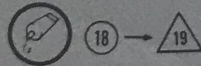

7

4X

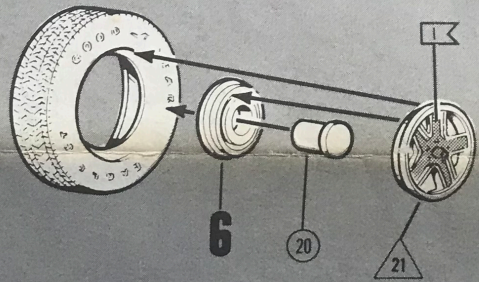

20 WHEEL RETAINER (4 PARTS)
 21 WHEEL - OUTSIDE HALF (CHROME) (4 PARTS)



8

23 EXHAUST SYSTEM
 24 FLOOR PAN
 25 UPPER FRONT SUSPENSION MEMBER

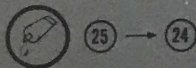
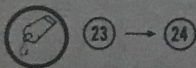
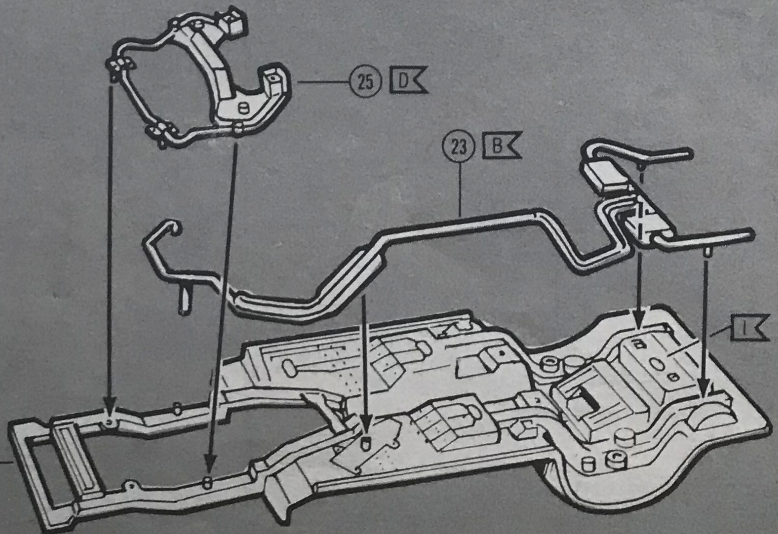

9

26 REAR BRAKE CALIPERS (2 PARTS) 27 REAR AXLE & DRIVE SHAFT 28 REAR SHOCK ABSORBERS (2 PARTS)

2X 26 → 27 2X 28 → 27

10

29 REAR COIL SPRINGS (2 PARTS)

2X 29 → 8 9 → 8

11

30 REAR TORQUE ARMS 31 REAR SWAY BAR

30 31 → 10

12

32 STEERING WHEEL 33 STEERING COLUMN 34 INSTRUMENT PANEL

32 → 33 → 34

13

35 SHIFT LEVER (CHROME) 36 FLOOR CONSOL 37 EMERGENCY BRAKE LEVER (CHROME)

35 37 → 36

14

2X

38 FRONT SEAT - BACK HALF 39 FRONT SEAT - FORWARD HALF

38 → 39

15

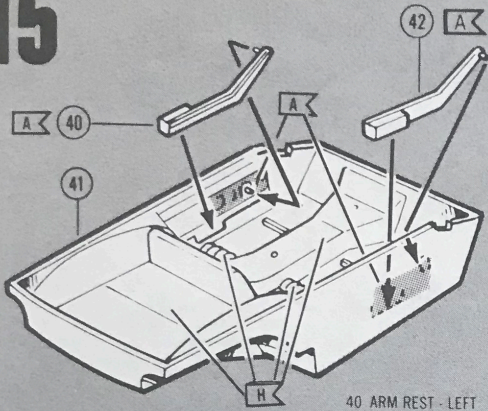

40 ARM REST - LEFT
41 INTERIOR PAN
42 ARM REST - RIGHT

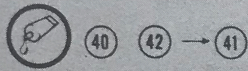

16

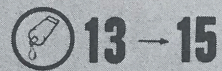
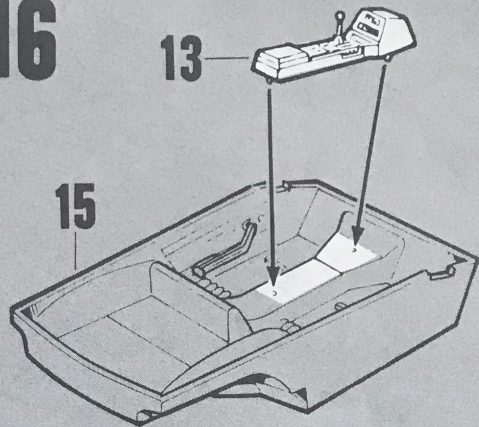

17

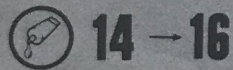
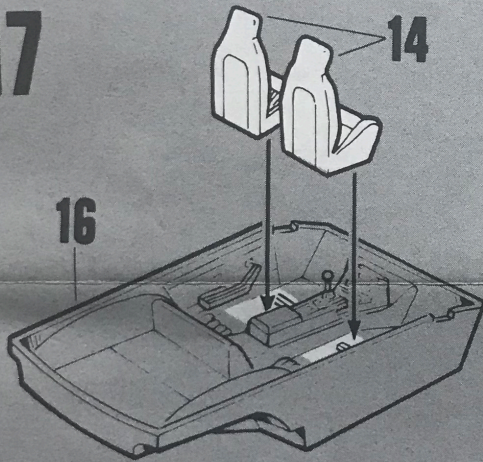

18

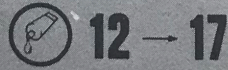
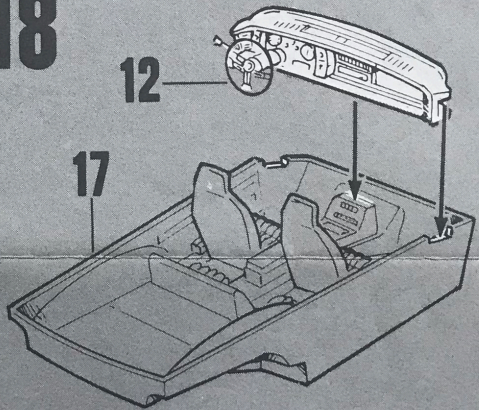

19

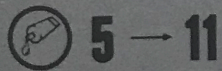
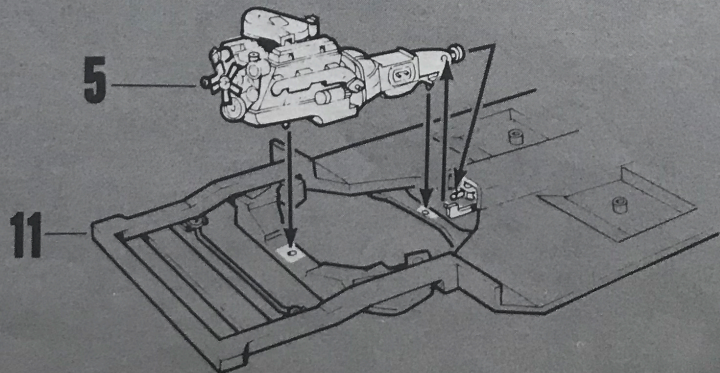

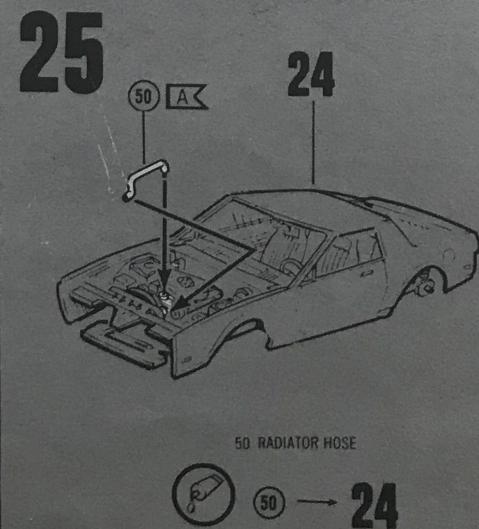
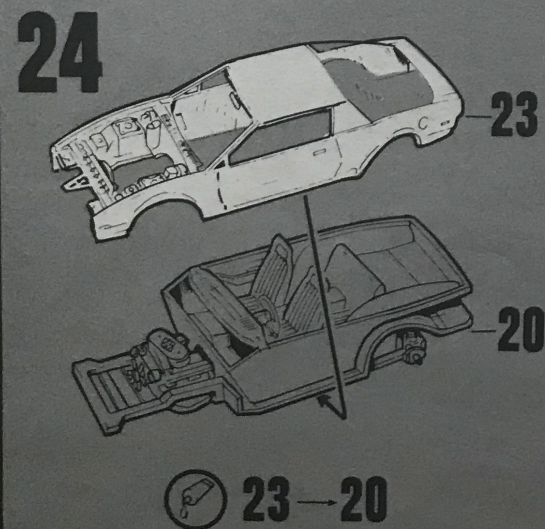
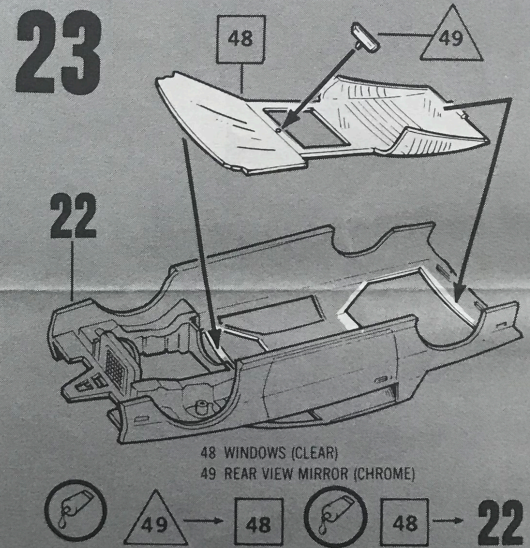
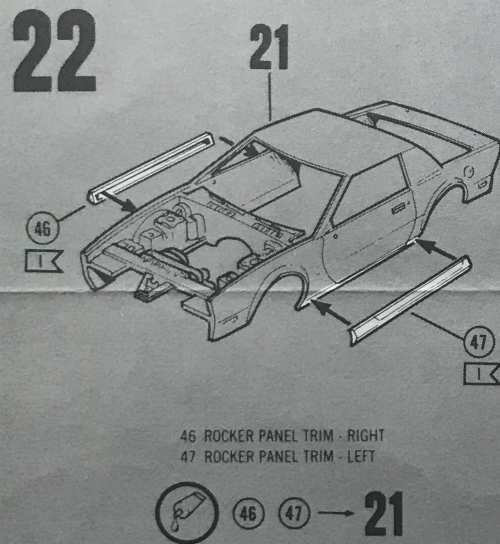
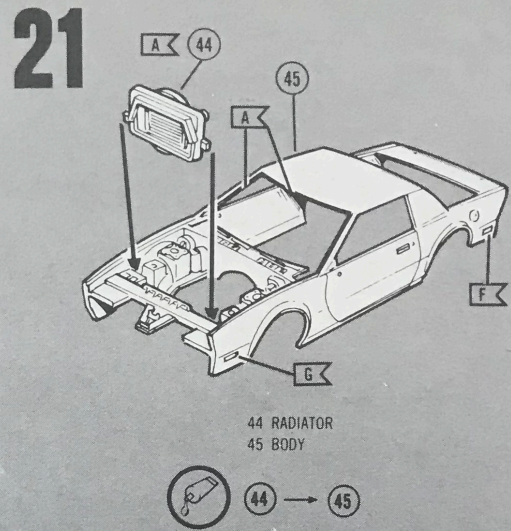
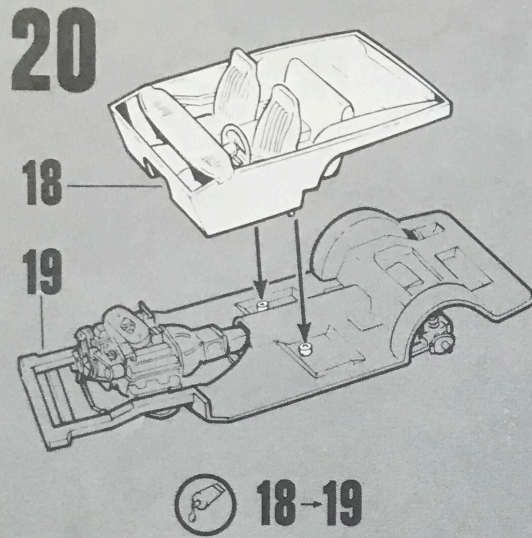

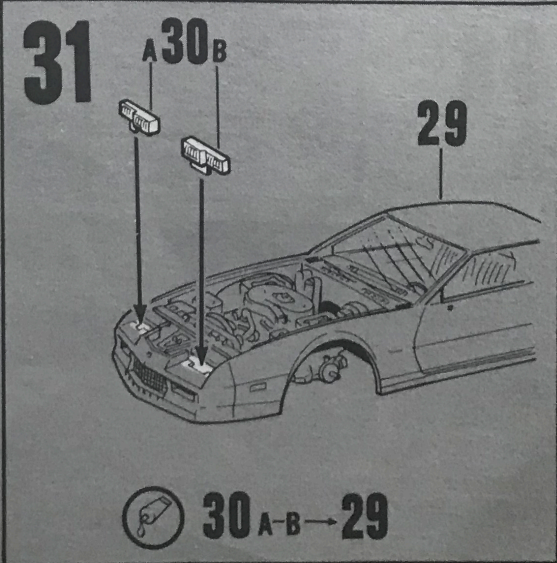
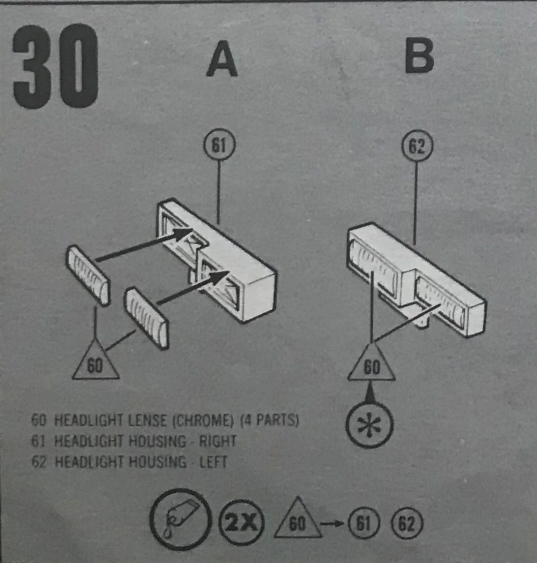
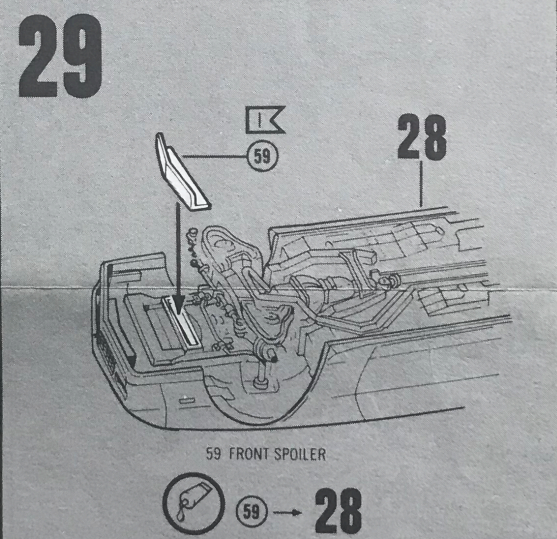
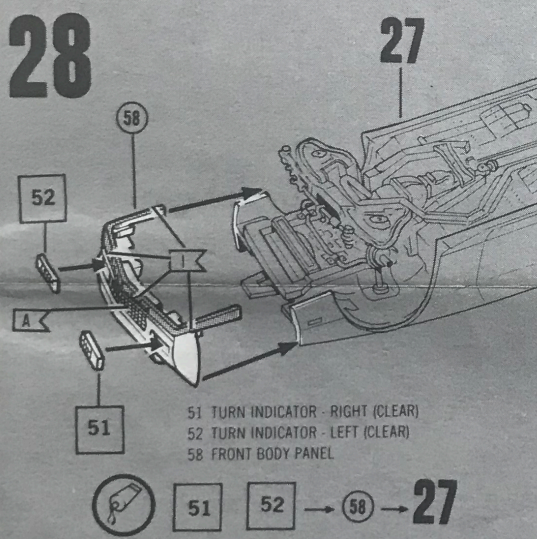
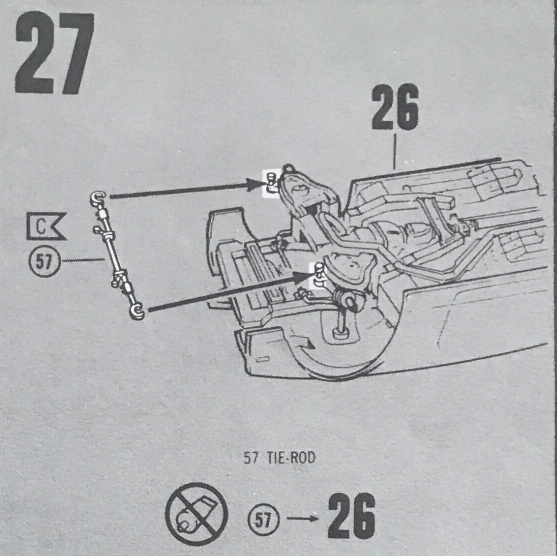
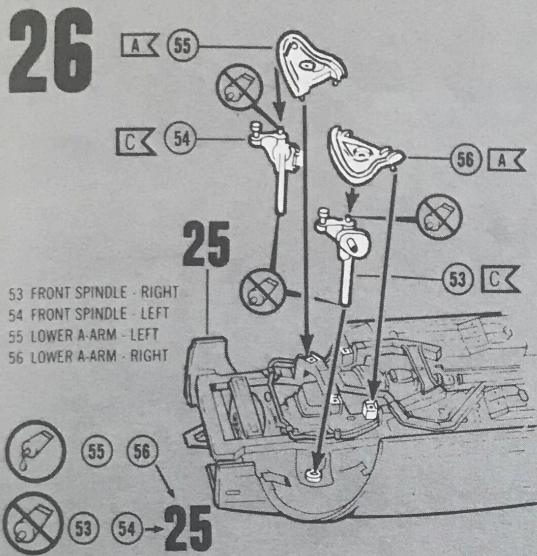

32

68 HOOD

68 → 31

33

69 REAR BUMPER
70 REAR SPOILER

69 70 → 32

34

71 TAILLIGHTS (CLEAR)

71 → 33

35

7 → 34

36

7248 © FORD MOTOR CO. 1974

10

2

1

3

4

5

6

7

8

9

10

73 MIRROR - LEFT (CHROME)
74 MIRROR HOUSING - LEFT

75 MIRROR - RIGHT (CHROME)
76 MIRROR HOUSING - RIGHT

73 → 74 → 35

75 → 76 → 35